

100mm Diameter Fan Range

General Arrangement

Type - 'W'

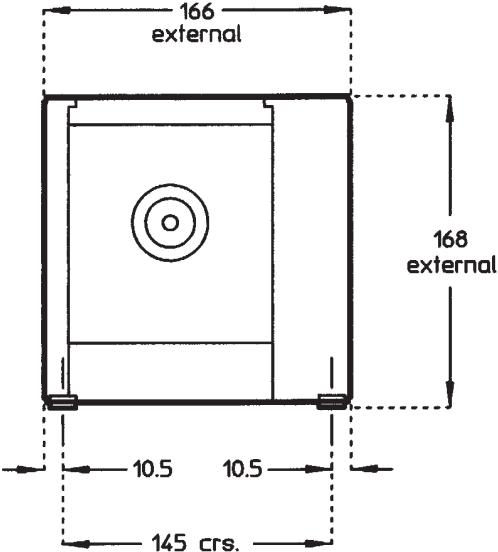

Drawn Left-Hand - 'WL'

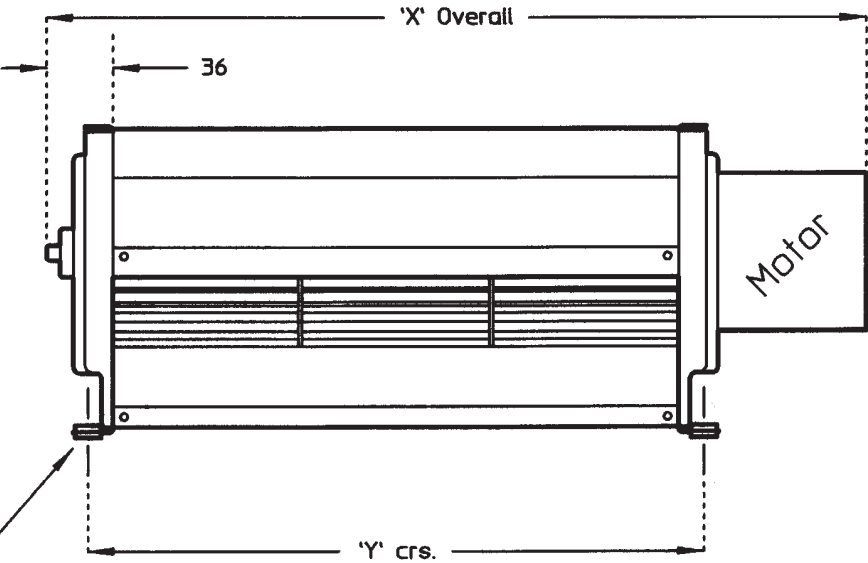

4 Grommet Feet.
Internal Dia. 6.0mm

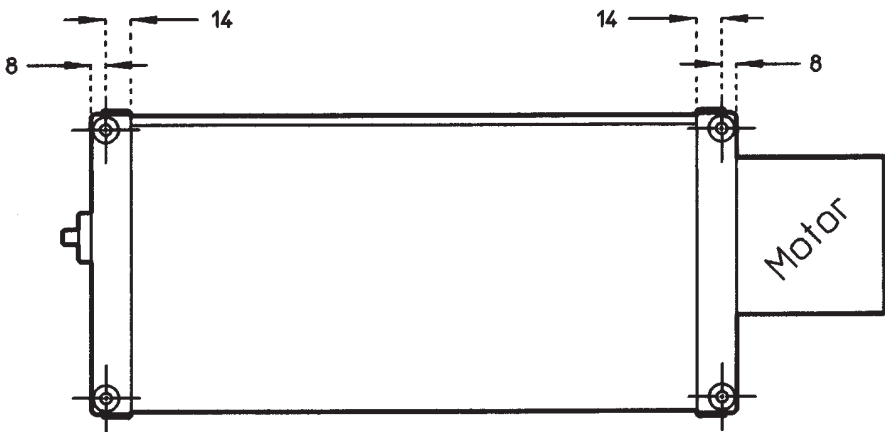

Table Range Code: W

Product Data Table

Style L,R or C (see GA)	Impeller Length (mm)	Motor Code	Free Air Flow (L/S)	Max Static Pressure (mm H ₂ O)	Free Air Speed (rpm)	Overall Length 'X' ±0.5mm (see GA)	Fixing Centres Dimension 'Y' ± 0.5mm (see GA)
L,R	300	4	100	3.5	1150	450.0	322.0
L,R	420	4	190	3.1	1216	600.0	442.0
L,R	550	4	225	3.1	1150	740.0	572.0
L,R	1000 (2x500)	4	570	5.5	1320	1190.0	1046.0

NOTES:

The above figures are examples of available crossflow fans.

Products are configured to suit customer's individual applications.

When fitted with a heating element the Product Range Code changes to X.

Two or three speed motors are available.