

FIG 3 - WIRING DIAGRAM

CLAUDGEN

INSTALLATION, OPERATION AND MAINTENANCE
INSTRUCTIONS FOR

Claudgen Screen-Zone

Warm Air 9kW Curtain Heater

Catalogue Number HE7433-21

PLEASE RETAIN THIS LEAFLET FOR FUTURE MAINTENANCE

CONSORT EQUIPMENT PRODUCTS LTD

REGISTERED OFFICE: THORNTON INDUSTRIAL ESTATE

MILFORD HAVEN, PEMBROKESHIRE, SA73 2RT

TEL: 01646 692172 FAX: 01646 695195

WEB: www.consortepl.com EMAIL: enquiries@consortepl.com

MODEL

This unit is a 990mm 9kW air curtain heater designed for mounting above entrances but may also be used as a space heater. It is supplied complete with remote mounting control box.

MOUNTING

When mounted over a standard shop doorway the unit should be fitted as low as possible and not more than 2.3 meters from ground level. A single unit will provide reasonable coverage for a one metre doorway, and for wider doorways units can be mounted end to end.

The unit should be positioned so that the airflow is not obstructed by any part of the doorframe.

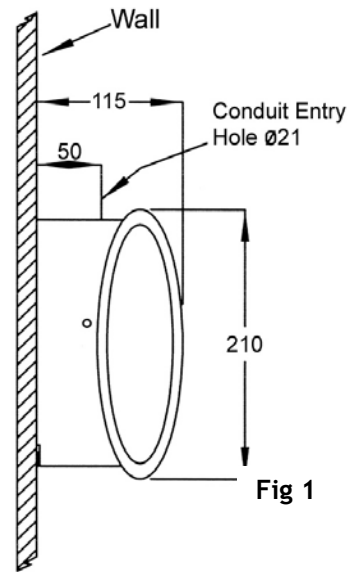
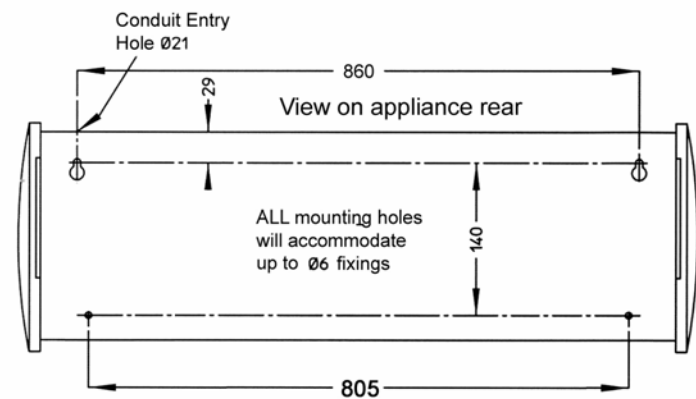

Fig 1 OUTLINE DRAWING

INSTALLATION

Carefully unpack the unit and remove the top cover fixing screws. The heater may be mounted using the mounting bracket provided.

Loosen mounting screws, allowing the mounting bracket to be removed from the unit. Making sure that the mounting bracket is horizontal, fix the bracket to the wall using 4 x No 8 wood screws.

Place the unit on the mounting bracket ensuring the washers are spaced as shown on diagram 2 (a plain washer either side of the mounting bracket).

Tighten screws to hold the unit at the required angle.

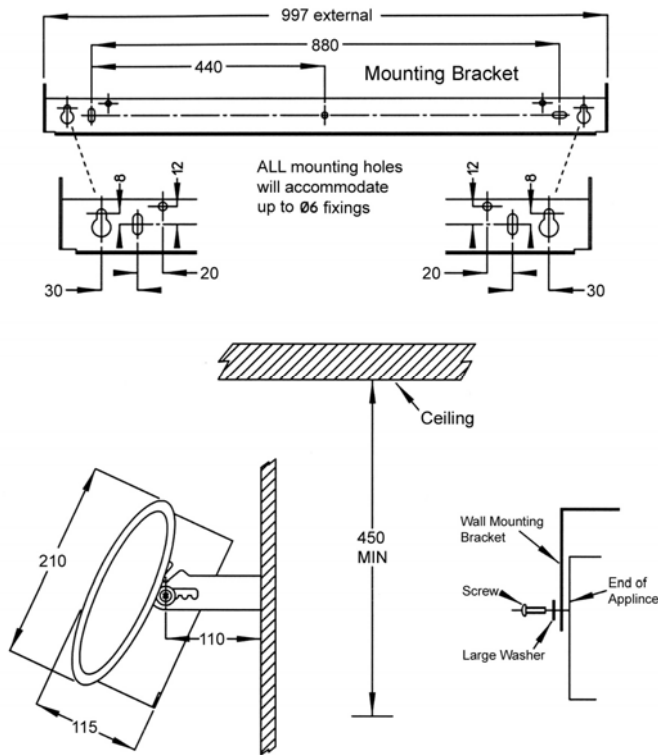

Fig 2 WALL BRACKET ASSEMBLY

The heater may also be mounted directly onto a suitable wall or bearer by four No. 8 wood screws through the holes provided in the back of the unit casing. Keyhole slots are provided for the top two fixings (fig 1).

ELECTRICAL CONNECTIONS

The heater is suitable for connection to a 415 volt 3 phase 50Hz supply. With modification the unit can also be on a 240 volt 50Hz supply. For 240 volt single phase operation, link terminals L1, L2 and L3 on the main input terminal block and connect the supply to L. The heater consumes approximately 9kW on the full heat setting. The connections to be made between the heater and the remote control box are shown in Fig 3 (see back page). An earth terminal is adjacent to the terminal block and is clearly marked with the symbol ⚡. For safety reasons a good earth connection must ALWAYS be made to the heater and control box.

The unit must be wired in accordance with IEE regulations for the Electrical Equipment of Buildings and the installer should ensure that a suitable fused isolating switch is connected in the mains supply.

CONTROL

The unit is designed to provide 2 levels of heat, 4.5kW and 9kW, together with 2 fan speeds, normal and boost. The remote control box houses 4 single pole switches to give the following functions:

- SWITCH 1 (left-hand) ON/OFF
- SWITCH 2 FAN SPEED CONTROL
- SWITCH 3 ½ HEAT ON/OFF
- SWITCH 4 ½ HEAT ON/OFF

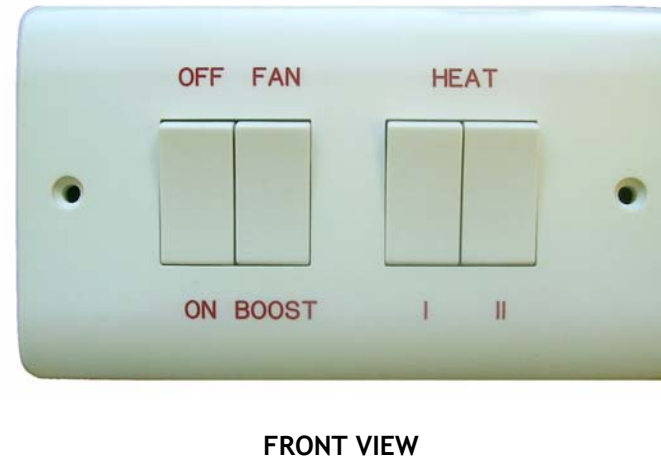
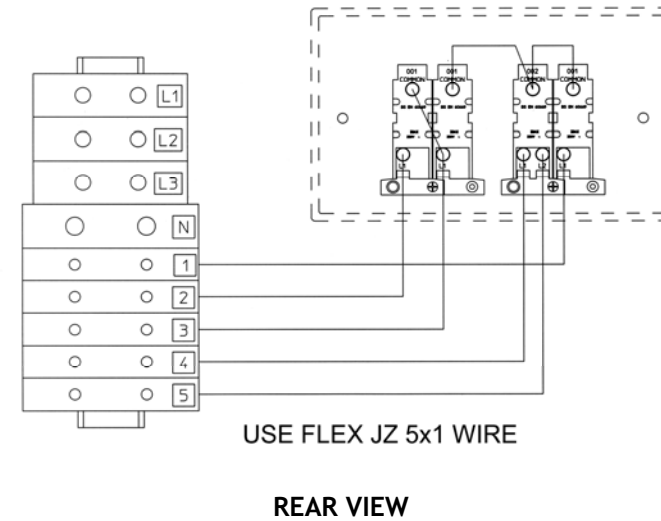

FIG 4 - REMOTE CONTROL SWITCH

MAINTENANCE

ALWAYS ENSURE THAT THE MAIN EXTERNAL ELECTRICITY SUPPLY IS SWITCHED OFF BEFORE SERVICING OF THIS SCREEN-ZONE HEATER.

To obtain the best results from the heater it is essential to avoid the accumulation of dust and dirt within the unit and on the inlet and discharge grilles. Regular cleaning is necessary with particular attention to the fronts and backs of the fan motor blades. Cleaning of the fan is best carried out with a soft brush.

PROTECTION (Thermal Cut-Out)

The unit is protected in the event of fan failure, or an obstruction of the free air flow, by a single thermal PTC Self Hold Cut-out. Having tripped the PTC Cut-out remains open, effectively switching off the heating elements, as long as mains power is available inside the appliance. The PTC Cut-out will only reset when the appliance is switched OFF and allowed to cool for at least 20 minutes.

TO RESET THE PTC SELF-HOLD CUT-OUT

DO NOT ADJUST ANY INTERNAL COMPONENTS BY HAND

- a) The cut-out is reset by switching OFF mains power to the appliance.
- b) Allow the appliance to cool for 20 minutes.
- c) Restart. Switch ON the appliance. The cut-out will be reset. If the cut-outs trip again a qualified electrician should be consulted.

TO REPLACE A SWITCH IN THE CONTROL BOX

- a) Switch off the mains supply
- b) Remove the switch box cover.
- c) Disconnect the wiring to the switch.
- d) Release the spring clips and push out the switch.
- e) Fit the replacement switch, reconnect the wiring and replace the cover.

SPARES

It is essential when ordering spares or replacement parts to state the model number HE7433 and the serial number on the rating plate fixed to the top of the unit.

NB: DO NOT COVER ANY OF THE AIR INLET OR OUTLET GRILLES AT ANY TIME.

In the interest of progress the Company reserves the right to vary specifications from time to time without notice. The material listed is offered subject to the Company's General Conditions of Sale, a copy of which can be obtained on request.