

INSTALLATION

Ensure the electricity supply is disconnected from any relevant fixed wiring before commencing the installation. Ensure that the mains supply voltage is as stated on the rating label.

The supply circuit must be adequate for the input of the appliance.

IMPORTANT

When installed in a bathroom the unit must not be connected via a plug and socket.

The heater must also be located in the appropriate zone of the bathroom, in accordance with section 601 of the Wiring Regulations BS 7671).

The appliance should be fitted horizontally such that the cable entry is uppermost and the pullcord is at the bottom.

The unit must be mounted a minimum of 1.8 metres from the floor, also a minimum of 150 mm below ceiling level or any other projecting surface. It must also not be less than 250 mm from any adjacent projecting surface.

The unit must not be located immediately below a fixed socket outlet.

Ensure that when in use the airstream is not obstructed by a cupboard or similar object.

WARNING – THIS APPLIANCE MUST BE EARTHED

WARNING – DO NOT PLACE AEROSOLS OR SIMILAR CONTAINERS OR MATERIALS SUSCEPTIBLE TO HEAT IN THE DIRECT AIRSTREAM.

CONNECTION TO THE MAIN SUPPLY

Electrical installation should be carried out by a competent installer, preferably registered with NICEIC (National Inspection Council for Electrical Installation Contracting) in accordance with the 16 edition of the IEE Wiring Regulations, (BS.7671) and any relevant Local Authority Bye-Laws.

The heater is fitted with a 3-core mains supply cable and should be permanently connected to the electricity supply via a double pole switch having 3 mm gap on each pole.

A switched Fused Connection unit to BS.1363 Part 4 is a recommended mains supply connection accessory to ensure compliance with safety requirements applicable to fixed-wiring installation.

MOUNTING PROCEDURE

Using the mounting bracket supplied as a template, position it horizontally a minimum of 1.92 m from floor to underside of bracket and mark the position of the three fixing holes (ref A. in diagram).

Drill and plug the wall suitable for No 8 screws.

Insert the two keyhole screws in wall leaving approximately 2 mm gap between head and wall.

Secure the mounting bracket to the appliance using the 3 No 6 screws supplied (ref B in diagram).

Position the appliance on the partially inserted wall screws and secure the third wall screw immediately above appliance.

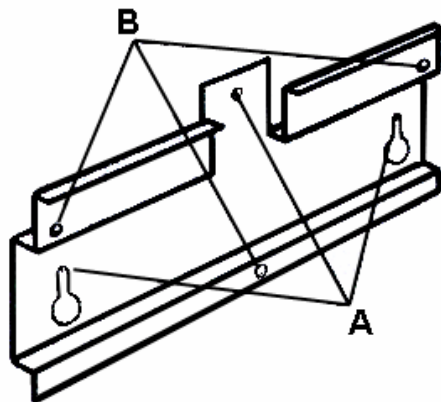

CONTROLS

The BFH2T has a heat loading of 2 kW. The heater is controlled by a pullcord operated on/off switch. A neon indicator when lit shows that the unit is operational.

The appliance is fitted with an Electronic Safety Control (ES). This is a safety device which switches off the heater if for any reason the appliance overheats. The ES Control can only be re-set after the appliance has cooled down. In order to re-set the ES Control proceed as follows:-

- Switch off appliance by means of pullcord and leave for approximately 5 minutes.
- Switch appliance back on and ES Control will re-set.
- Ensure that the appliance is functioning correctly. If the ES Control operates again, the appliance should be checked by a competent electrician.

THERMOSTAT CONTROL

The BFH2T is fitted with a thermostat.

To set the thermostat to the required temperature, turn the control knob fully clockwise. When the desired room temperature is reached, turn the knob slowly anti-clockwise and when the thermostat 'clicks' off, leave the control at this setting. Thereafter, the fan heater will control the heat output automatically.

To set the heater to the Frost Watch mode, rotate the thermostat control knob fully to the lowest setting (N° 1). Thereafter the heater will trip in if the temperature drops sufficiently. The heater needs to be in the 'ON' mode with the neon indicator light illuminated for this function to operate.

THERMOSTAT CONTROL KNOB

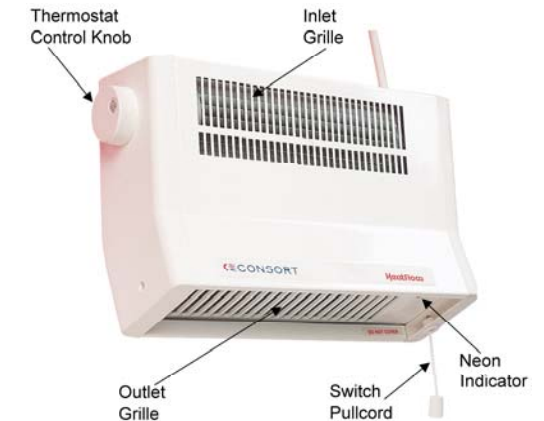
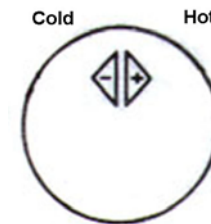

IF YOUR HEATER DOES NOT WORK

- Check re-set of E.S. Control as described under 'controls'.
- Check that the plug is firmly pushed into the wall socket with the socket switched 'on'.
- Check that the socket is live by using another appliance in it. (If it is not live, check the fuse at the distribution board).
- Check that the plug is wired correctly.
- Check that the fuse has not blown. (This can be done by replacement with another suitable fuse).
- If you are replacing a fuse in the plug, a 13 Amp fuse approved by A.S.T.A to BS 1362 must be used.
- Should none of the above remedies work, than disconnect heater from the mains and consult an accredited service agent.
- Do **NOT** attempt to repair the heater or unscrew the outer casing yourself.

SAFETY

This equipment has been designed and manufactured to the highest international standard, but, like all electrical appliances which are operated by mains voltage, care must be taken if you are to obtain the best results and safety is to be assured.

- Do NOT handle the appliance with wet hands.
- Do NOT use the appliance in workshops or rooms where excessive dust is generated or present.
- Ensure that nothing is pushed into any aperture of this appliance.
- Do NOT touch outlet grille when appliance is in use.

This appliance meets the requirements of EU Directive 89/336/EEC for EMC.

CLEANING

Always disconnect the heater from the mains before cleaning.

The fan heater should not require any maintenance, but it is strongly advised that it be kept clean. An occasional wipe over with a soft cloth is all that should be necessary.

- Do NOT use metal or furniture polish on any part of the heater
- Do NOT touch the heater with wet hands or in any way bring water in contact with it.

The supply cord on this appliance can only be replaced by the use of special tools, and should any damage or fault occur to the heater, it must be serviced by an accredited service agent.

IMPORTANT:

ALWAYS RETAIN YOUR USER INSTRUCTIONS FOR FUTURE REFERENCE.

GUARANTEE

This guarantee is offered to you as an extra benefit and does not affect your legal rights.

All electrical appliances produced for the Company are guaranteed for one year against faulty material or workmanship. This applies only if the appliance has been used for purposes in accordance with the instructions provided and has not been connected to an unsuitable electricity supply, or subject to misuse, neglect, damage or modified or repaired by any person not authorised by us.

The correct electricity supply voltage is shown on the rating label attached to the appliance.

Please retain your receipt as proof of purchase.

CUSTOMER HELPLINE

Should you need any advice on the use of your new Consort product, or should you require service or repair, please contact our Helpline:

☎ 01646 692172 Mon to Fri 8.30 am to 3.30 pm

Consort Equipment Products Limited

Thornton Industrial Estate, Milford Haven, Pembrokeshire, SA73 2RT

Fax: 01646 69519 Email: enquiries@consortepl.com Web: www.consortepl.com

CONSORT

Quality Space Heaters

Using and Looking after your

HEATFLOW

Wall Fan Heater

BFH2T

