

INSTALLATION, OPERATION and MAINTENANCE INSTRUCTIONS for RECESSED WARM AIR CEILING HEATER Catalogue Numbers HE7245 4.5 kW and HE7260 6 kW

RETAIN THIS LEAFLET FOR FUTURE MAINTENANCE

The Claudgen recessed ceiling heater is designed to fit in place of a standard 600mm ceiling panel. It is supplied complete with a remote mounting control box.

IT IS ESSENTIAL THAT THE CEILING FRAME IS ADEQUATELY SUPPORTED TO SUPPORT THE WEIGHT OF THE HEATER, OR THAT THE HEATER IS INDIVIDUALLY SUPPORTED. THERE IS PROVISION ON THE HEATER FOR CHAIN OR WIRE, SUPPORT OR MOUNTING.

Weight: 13 Kg.

INSTALLATION

Carefully unpack the unit and control box. The unit is supplied with a length of self-adhesive foam strip. This can be cut into lengths and is to be laid on the 4 sides of the ceiling frame (see Fig 4). This will ensure that the unit assembly is free from vibration. The discharge grille and diffuser assembly can now be fitted into the ceiling frame (see fig 4).

ELECTRICAL CONNECTIONS

This unit is suitable for connection to 230/240V 50Hz supplies.

The HE7245 has a heating load of 4.5 kW
The HE7260 has a heating load of 6.0 kW

The connection to be made between the heater and the remote control box are shown in Fig 3. An earth terminal is adjacent to the terminal block and is clearly marked with the symbol .

For safety reasons a good earth connection must ALWAYS be made to the heater and control box.

The unit must be wired in accordance with I.E.E regulations for the Electrical Equipment of Buildings and the installer should ensure that a suitable isolating switch is connected in the mains supply.

Fig. 2 shows wiring diagram.

The electrical connections are accessible so that the unit can be wired in situ (see Fig 1).

CONTROL

The remote control box houses 2 double pole 20 amp rocker switches and gives the following functions:

SWITCH 1 (LH)	OFF/FAN ONLY
SWITCH 2	FULL HEAT

MOUNTING

The fan heater box can only be fitted one way round (see Fig.1), as 2 of the studs are off-set. This ensures that the fan outlet lines up with the discharge grille and also that the wiring is always sighted the same side.

The diffuser is attached to the discharge grille with 4 small clips, which can be removed if necessary.

The discharge grille has 4 additional studs, plus nuts/washer, to enable the unit to be chain mounted, if required.

There are also extra holes in the box to enable the unit to be suspended via wires.

MAINTENANCE

ALWAYS ENSURE THAT THE MAIN EXTERNAL ELECTRICITY SUPPLY IS SWITCHED OFF BEFORE SERVICING THIS HEATER.

To obtain the best results from the heater, it is essential to avoid the accumulation of dust and dirt within the unit on the air inlet and discharge grilles. Regular cleaning is necessary with particular attention to the removal of any dirt on the fan rotor blades. Cleaning of the fan is best carried out with a soft brush.

PROTECTION (Thermal Cut Out)

The unit is protected in the event of fan failure, or an obstruction of the free air flow, by a thermal PTC Self Hold Cut Out. Having tripped the PTC Cut Out remains open, effectively switching off the heating elements, as long as mains power is available inside the appliance. The PTC Cut Out will only reset when the appliance is switched OFF and allowed to cool for at least 20 minutes.

To reset the PTC Self Hold Cut Out

DO NOT ADJUST BY HAND ANY INTERNAL COMPONENTS

- The cut-out is reset by switching OFF mains power to the appliance.
- Allow the appliance to cool for 20 minutes
Re-start, switch ON the appliance. If the Cut-out trips again, a qualified electrician should be consulted.

TO REPLACE A FAN/HEATER ASSEMBLY

- Switch off the mains supply
- Release the air inlet duct from both the fan heater box and the discharge grille panel.
- Release the six nuts and washers fixing the fan heater box to the discharge grille panel.
- Disconnect the fan heater wiring from the mains terminal block and earth stud.
- Remove the fan heater from the box (four screws).
- Fit replacement unit and re-assemble in the reverse order.

TO REPLACE A SWITCH IN THE CONTROL BOX

- Switch off the mains supply
- Remove the switch box cover
- Disconnect the wiring to the switch
- Release the spring clips and push out the switch
- Fit the replacement switch, reconnect the wiring and replace the cover.

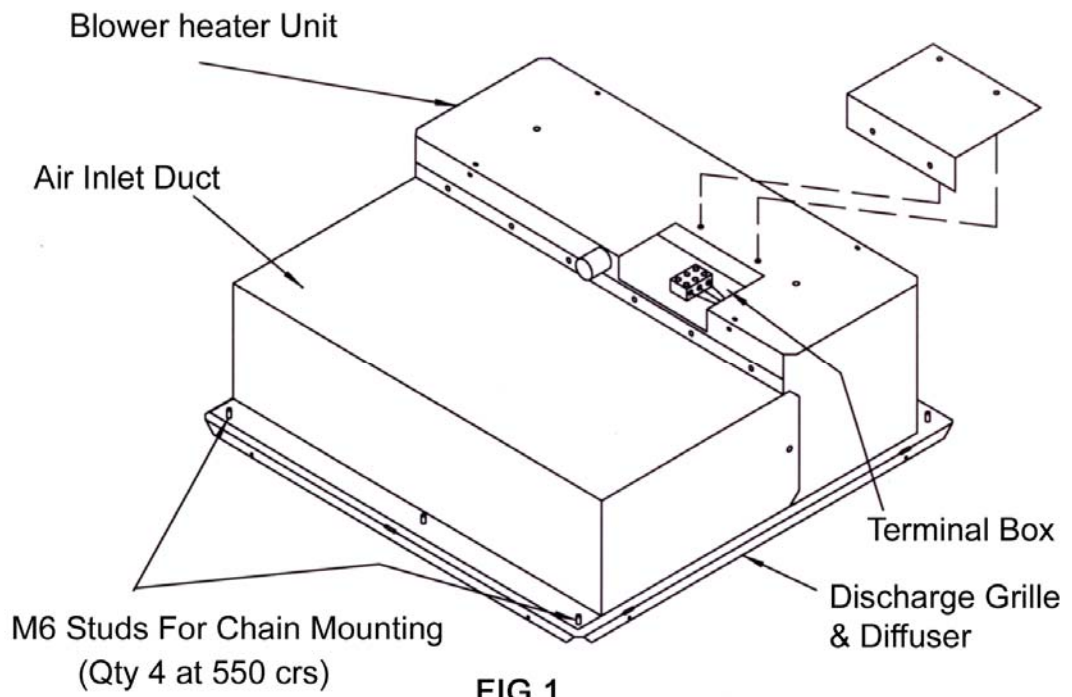

FIG 1

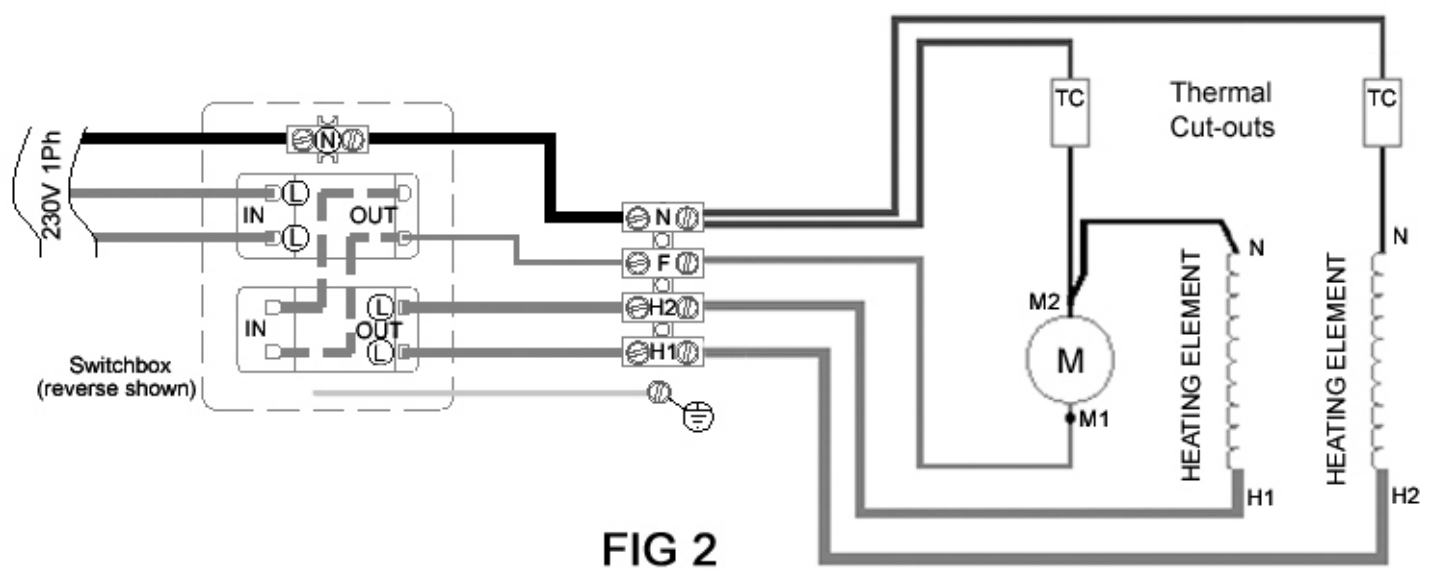

FIG 2

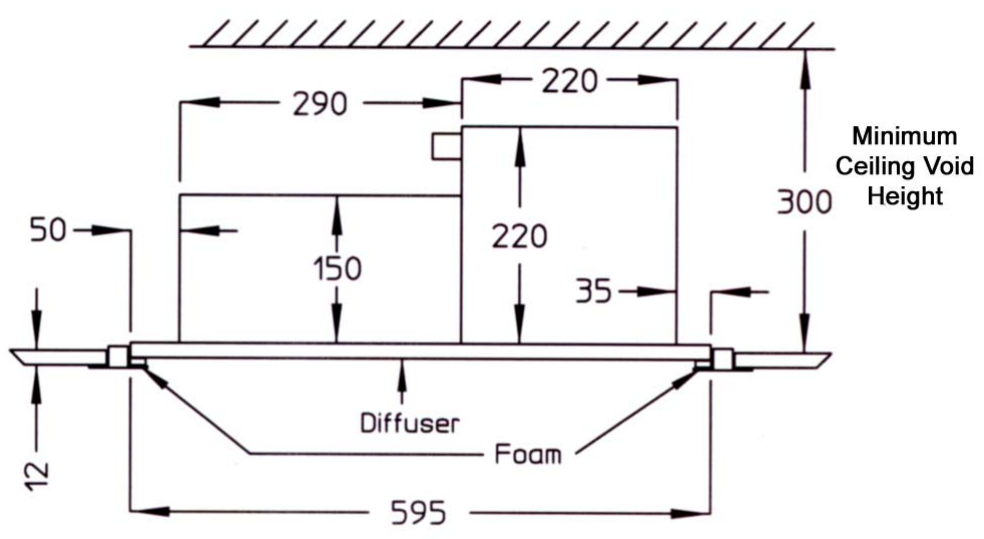

FIG 3