

SAFETY

When using any electrical appliance, basic safety precautions should always be observed. Please read these instructions carefully and retain for future use.

- The appliance is not intended for use by persons (including children) with reduced physical, sensory or mental capabilities, or lack of experience and knowledge unless they have been given supervision or instruction concerning use of the appliance by a person responsible for their safety. Young children should be supervised to ensure that they do not play with the appliance.
- This appliance is intended to dry towels and therefore is hot to the touch. Any rise in ambient temperature is directly reflected in the appliance, and as a result of this the appliance will feel hotter to the touch during warmer periods. Also the insulation effect of towels will cause the operating temperature to increase slightly.
- The avoid a hazard this heated towel rail **MUST NOT** be used to carry towels or any other articles that have been in contact with oil, petroleum based products or dry cleaning fluids.
- Use this appliance only on the voltage specified on the rating label.
- Do **NOT** use this towel rail unless it has been fitted to the wall as per these instructions.
- Do **NOT** immerse in any liquid.
- Do **NOT** allow the supply cable to come into contact with heated surfaces during operation.
- The towel rail and flexible cable outlet must be mounted so that no part of them can be touched by any person using a bath or shower.
- Do **NOT** use the appliance if damaged.

SPECIFICATIONS

DIMENSIONS				
Model:	TRF30 LST	TRJ40	TRJ60	TRJ80
Width:	450mm	460mm	485mm	535mm
Height:	410mm	410mm	660mm	860mm
Depth:	85mm	85mm	85mm	85mm
Weight:	1.9 kg	1.9 kg	2.5 kg	3.3 kg
ELECTRICAL				
Wattage:	27-30 W	42-45 W	60-65 W	84-85 W
Supply:	230-240 Volts ac 50 Hz, single phase			
Ingress Protection Rating: IP34 - Splashproof - Double Insulated				

This towel rail meets the requirements of EU Directive 89/336/EEC (Amended by 92/31/EEC) for Electromagnetic Compatibility.

Please note, the TRF30 LST is a **Low Surface Temperature** model which has a **maximum surface temperature of 43°C** to comply with Department of Health guidelines.

INSTALLATION

Ensure the electricity supply is disconnected from any relevant fixed wiring before commencing the installation.

This appliance **MUST** be connected in accordance with the latest IEE regulations and fitted by a competent electrician. The supply circuit must be adequate for the input of the appliance. The towel rail must be connected via a fused, double pole, switched (having a contact separation of at least 3mm in each pole), flexible cable outlet and fitted with a 3 Amp fuse or via a plug and socket.

When installed in a bathroom, the towel rail must **NOT** be connected via a plug and socket. The towel rail must also be located in the appropriate zone of the bathroom, in accordance with section 601 of the Wiring Regulations BS 7671:1992 (Amendment 10983).

NOTE: This class II appliance does **NOT** require earthing.

MOUNTING PROCEDURE

Choose a suitable position on the wall to mount the heated towel rail. The cable entry can be either on the left or right hand side, but it must be horizontal and at the bottom of the frame.

WARNING: In order to avoid a hazard for young children, the wall mounted towel rails must be installed so that the lowest heated rail is at least 600 mm above the floor.

1. Slightly loosen off the screw inside each leg bracket and swivel the leg brackets around 90° the rear of the frame.
2. Should you require the cable to be at the other side, remove the screw and strap from each leg bracket, rotate the brackets 180° and refit the brackets to the rear of the frame.
3. Place the towel rail on a flat surface, check that all the leg brackets are sitting parallel and then tighten the screws enough to hold the brackets firmly against the frame, without over-tightening.
4. Level up the top rail of the heated towel rail and fasten to the wall with either the screws provided or with suitable toggle bolts.
5. Fit the screw caps to cover the screw holes in each leg bracket.

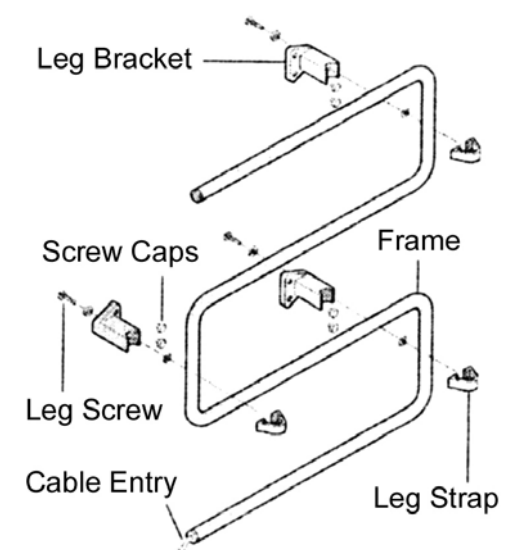

Figure 1 : TRJ60 Assembly

OPERATION

Your Consort Heated Towel Rail costs less to run than a 100 Watt light bulb. It will take approximately 45 minutes to reach operating temperature and, if need be, can be left running continuously.

CLEANING

Your heated towel rail is best wiped down from time to time with a damp cloth. Do not use any abrasive or corrosive cleaners. Always switch the appliance off before cleaning.

IF YOUR TOWEL RAIL DOES NOT WORK

Check that the fuse has not blown at the flex outlet, in the plug or at the distribution board. Do NOT attempt to repair the towel rail. Should none of the above remedies work then consult an accredited service agent. If the appliance is still under guarantee, return it to your supplier.

GUARANTEE

This guarantee is offered to you as an extra benefit and does not affect your legal rights. All electrical appliances produced for the Company are guaranteed for one year against faulty material or workmanship. This applies only if the appliance has been used for purposes in accordance with the instructions provided and has not been connected to an unsuitable electricity supply, or subject to misuse, neglect, damage or modified or repaired by any person not authorised by us.

CUSTOMER HELPLINE

Should you need any advice on the use of your new Consort product, or should you require service or repair, please contact our Helpline:

01646 692172 Mon to Fri 8.30 am to 3.30 pm

Consort Equipment Products Limited

Thornton Industrial Estate, Milford Haven
Pembrokeshire, SA73 2RT

Fax: 01646 695195

Email: enquiries@consortepl.com Web: www.consortepl.com

46000134 Iss 01

CONSORT

Installation and Operating Instructions

Towel Dry Towel Rails

Models: TRF30 LST, TRJ40, TRJ60, TRJ80

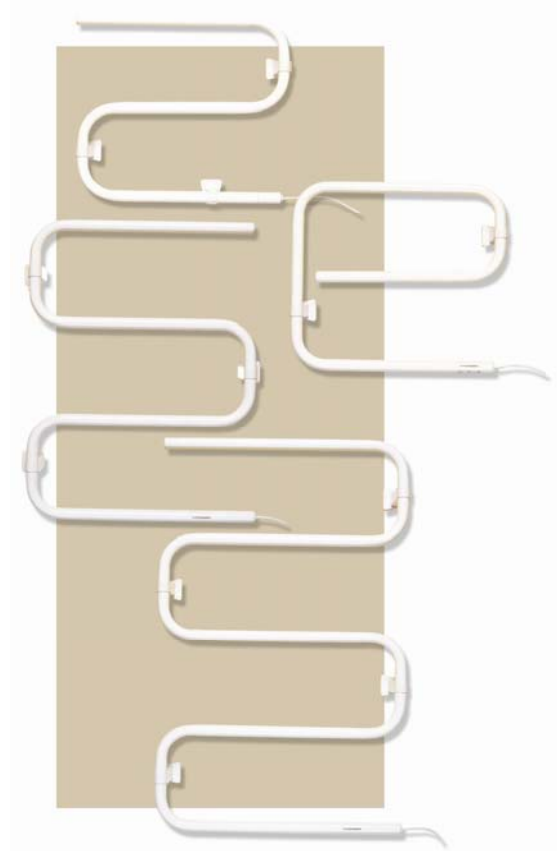

PLEASE READ THESE INSTRUCTIONS AND RETAIN FOR FUTURE REFERENCE
